

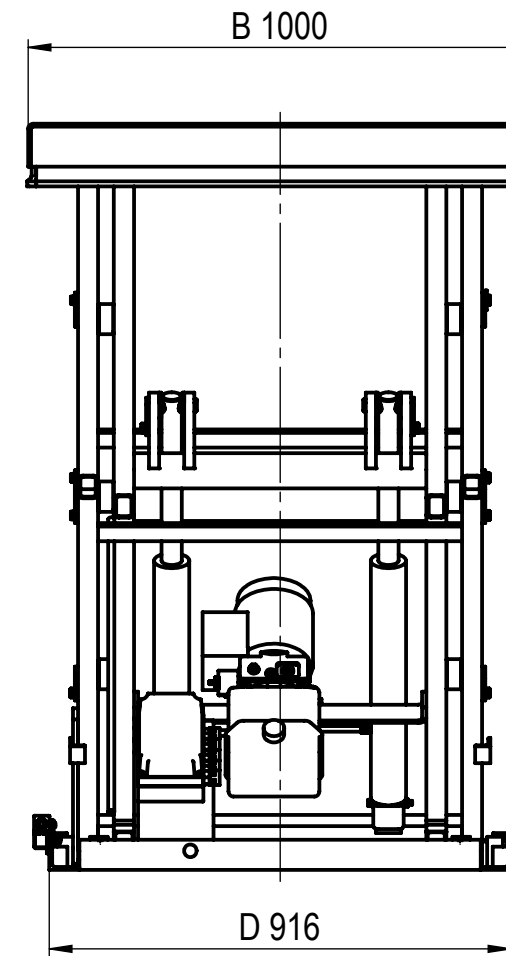

# HTP ERGONOMIZER

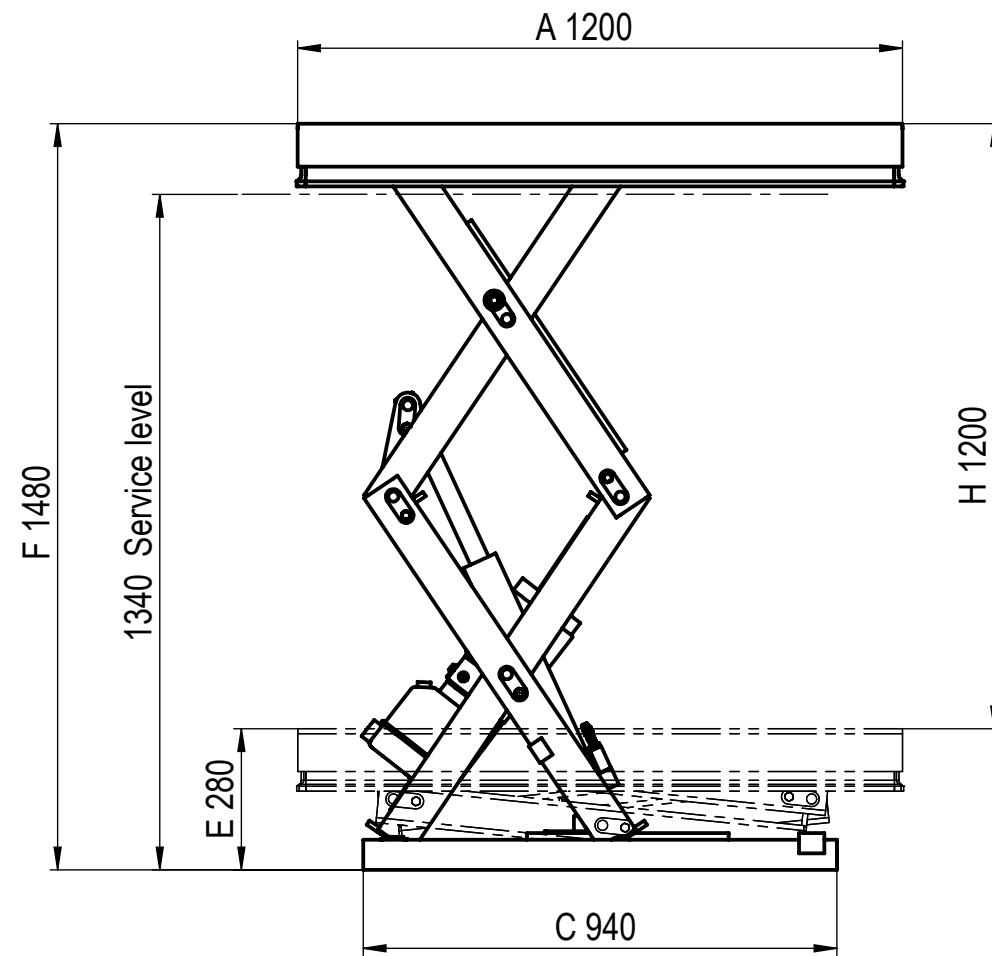

Subject to change. | Änderungen vorbehalten. | Sous réserve de modifications.

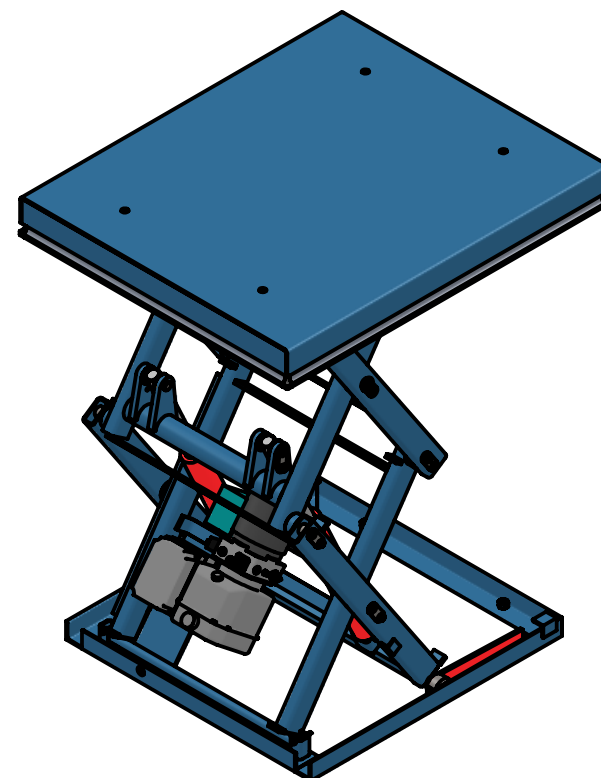

Capacity / Tragfähigkeit / Capacité (Full surface load / Flächenlast / Pleine charge de surface)	500	[kg]
Max Lifting / Max Hub / Hauteur de Levage max	1200	[mm]
Lifting Time / Hubzeit / Temps de course	30	[sek]
Required Power / Motorleistung / Puissance Moteur	1,5	[kW]
Power Supply / Stromversorgung / Tension d'alimentation	3x400V 50Hz	
Lifting Category / Hubkategorie / Catégorie de Levage	2	
Class of Protection / Schutzklasse / Classe de protection	IP54	
Color / Farbe / Couleur	RAL 5015	

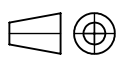
		Part name			HTPD 5 - 1200 1200x1000			Quantity:	
		Drawing nr			0179.17 00-00 HTPD-5-1200 -K13			Weight:	
		Dimension in	Sheet	Size	Scale	Index	Date		
		mm	1 / 2	A3	1:15	MK	2017-10-09		
<small>General tolerances for nominal dimension without specified tolerance: IT 13 The Information Contained In This Drawing Is The Sole Property Of Columbus Mckinnon Corporation. Any Reproduction In Part Or As A Wholewithout The Written Permission Of Columbus Mckinnon Corporation Is Prohibited.</small>									